

A high quality grinding machine that is mainly used by the demanding DIY enthusiast. The superior quality of this modern machine guarantees many years of enjoyable DIY work.



DS 4150T

Key to codes

- DS double grinder
- 4150 series 4000 / ø 150 mm
- T table model





## DS 4150T

1~

Voltage: 230V 1~ 50-60 Hz

art. 001100

Power: 250 W

Speed: 2800-3400 rpm

Grinding wheel d1 x b x d2: 150 x 20 x 15 mm

UK version art. 001122

## Features

- quality product
- power 250 Watt
- reliable
- low-vibration
- low noise level
- modern-day design
- 3 year warranty



Grinding wheel ø 150 mm



Practical hand-grip



Rigid, high strength polycarbonate eye shields



Easily accessible grinding wheels



Grinding supports with milled nuts



Retail pack



## Accessories



Hand dresser  
125 x 20 x 20 mm  
**art. 900251**



Wall console pro-support  
270 x 220 x 180 mm  
**art. 900317**



Grinding wheel  
ø 150 x 20 x 15 mm,  
grit 36  
**art. 700117**

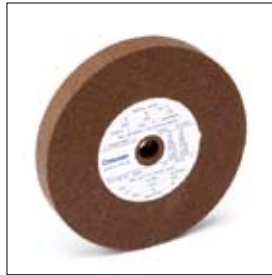

Grinding wheel  
ø 150 x 20 x 15 mm,  
grit 80  
**art. 700128**



Grinding wheel  
ø 150 x 20 x 15 mm,  
grit 100  
**art. 700392**

## Parts



Switch 2 pole black  
**art. 449010**



Grinding support  
left and right per 2 pieces  
**art. 1330085**



Eye shield  
universal per 2 pieces  
**art. 900009**



Eye shield  
with spark arrestor  
per 2 pieces  
**art. 900900**



Capacitor 4uf  
**art. 460020**



Flange 50/15.1 x 4 mm  
**art. 200420**



Flange 50/12.1 x 4 mm  
**art. 200409**



Nut M12 left  
**art. 668558**



Nut M12 right  
**art. 668437**



Creusen Powerline products are known for their quality, durability and reliability. This series of grinding and polishing machines is mainly used by professionals in the construction industry, workshops, garages and painting firms.





The machines in the Creusen Powerline range are very powerful. Whilst retaining one or both grinding functions, these double grinding machines can be extended by adding many accessories for various applications. The grinding and polishing machines comply with many international standards and have a strikingly modern and recognisable design.





The double grinding machines offer plenty of power and low-vibration operation.



DS 7200T

#### Key to codes

- DS** double grinder
- 7150** series 7000 / ø 150 mm
- 7200** series 7000 / ø 200 mm
- T** table model
- S** special, aluminium oxide wheel



**Creusen**  
POWERLINE



## DS 7150T

1~

Voltage: 230V 1~ 50-60 Hz

art. 002002

Voltage: **110V 1~** 50-60 Hz

art. 002167

Power: 350 W

Speed: 2800-3400 rpm

Grinding wheel d1 x b x d2: 150 x 20 x 15 mm

UK version art. 002123

## DS 7150TS

1~

Voltage: 230V 1~ 50-60 Hz

art. 002420

Power: 350 W

Speed: 2800-3400 rpm

Grinding wheel left d1 x b x d2: 150 x 40 x 15 mm

Grinding wheel right d1 x b x d2: 150 x 20 x 15 mm

UK version art. 002508

## Applications

DS 7150T

DS 7150TS



**DS 7150TS:**

Combination chisel sharpening and drill sharpening attachment

**DS 7150T/TS:**

Drill sharpening attachment

**DS 7150TS:**

Chisel sharpening attachment



Chisel sharpening attachment for the sharpening of wood chisels and many other chisels for metalworking



The clamping of paint scrapers



Drill sharpening attachment for grinding drills with a diameter of 3 to 18mm with a max length of 190 mm



Polishing



Steel-wire brush for derusting or deburring many types of tools or objects



Wall console pro-support



Pedestal universal K 7000





## DS 7200T

1~

Voltage: 230V 1~ 50-60 Hz

art. 002640

Voltage: **110V 1~** 50-60 Hz

art. 002750

Power: 600 W

Speed: 2800-3400 rpm

Grinding wheel d1 x b x d2: 200 x 25 x 15 mm

UK version art. 002673

DS 7200T on pedestal  
K 7000

Polishing

# Creusen Powerline Double grinder low speed

The DS 7500TS model is a machine with a low rpm rate, which makes it particularly suitable for the woodworking sector. A low-vibration machine for grinding all sorts of hard metal tools, such as chisels and gouges. The machine is fitted with two wide aluminium oxide grinding wheels, grit 100 and 60.



## DS 7500TS

1~

Voltage: 230V 1~ 50-60 Hz

art. 003069

Power: 350 W

Speed: 1400-1700 rpm

Grinding wheel d1 x b x d2: 150 x 40 x 15 mm

UK version art. 003080

## Features

- low rpm ensures accurate and steady grinding
- burn-out of tools practically eliminated
- two wide aluminium oxide grinding wheels



Chisel sharpening  
attachment for DS 7500TS  
art. 900200

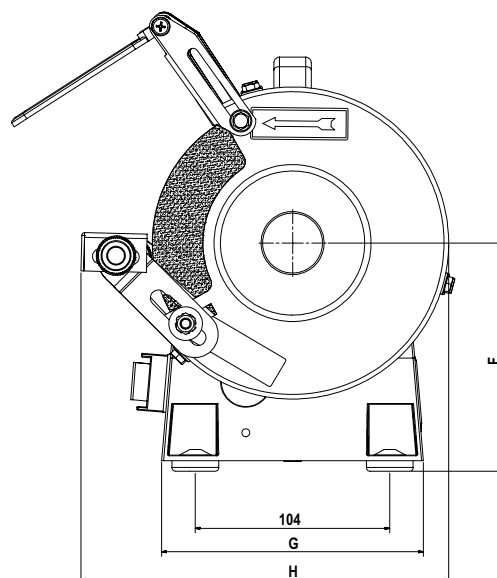
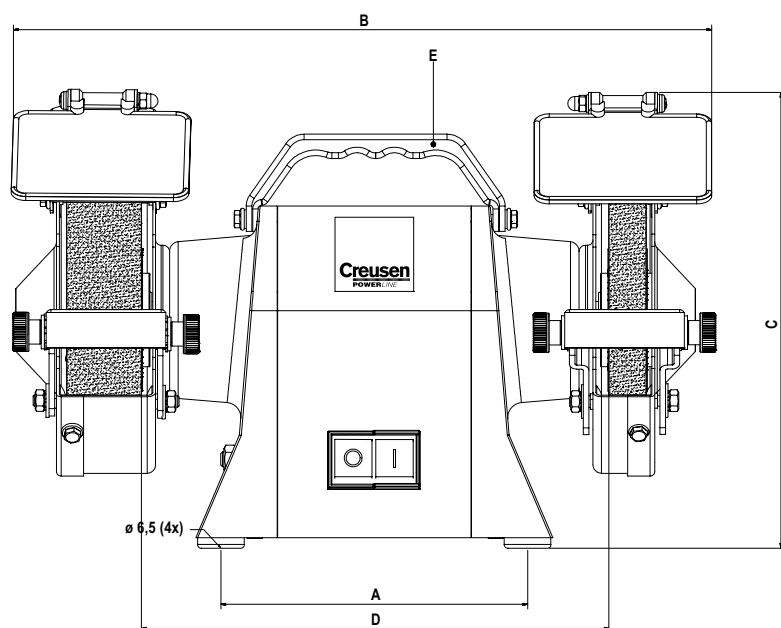

Type	A	B	C	D	E	F	G	H
DS 7150T	160	365	245	250	●	123	140	200
DS 7150TS	160	375	245	250	●	123	140	200
DS 7200T	185	405	275	280	-	123	140	260
DS 7500TS	185	405	245	275	-	123	140	160

Type	DS 7150T 1~	DS 7150T 1~	DS 7150TS 1~	DS 7200T 1~	DS 7200T 1~	DS 7500TS 1~
<b>Voltage (V)</b>	230	110	230	230	110	230
	1~	1~	1~	1~	1~	1~
<b>Frequency (Hz)</b>	50-60	50-60	50-60	50-60	50-60	50-60
<b>Power (W)</b>	350	350	350	600	600	350
<b>Speed (rpm)</b>	2800-3400	2800-3400	2800-3400	2800-3400	2800-3400	1400-1700
<b>Peripheral speed (m/s)</b>	22-26	22-26	22-26	30-36	30-36	11-13
<b>Grinding wheel d1 x b x d2 (mm)</b>	150 x 20 x 15	150 x 20 x 15	150 x 40 x 15	200 x 25 x 15	200 x 25 x 15	150 x 40 x 15
<b>Grinding wheel right d1 x b x d2 (mm)</b>			150 x 20 x 15			150 x 40 x 15
<b>Grit</b>	36/80	36/80	100/80	36/80	36/80	60/100
<b>Noise level dB (A)</b>	45	45	45	55	55	55
<b>Weight (kg)</b>	9	9	10	15	15	12
<b>Article number *</b>	002002	002167	002420	002640	002750	003069
<b>UK version article number</b>	002123		002508	002673		003080
<b>* Other versions on request</b>						
<b>Key to codes</b>						
<b>DS</b>	double grinder					
<b>7150</b>	series 7000 / ø 150 mm					
<b>7200</b>	series 7000 / ø 200 mm					
<b>T</b>	table model					
<b>S</b>	special aluminium oxide wheel					
<b>●</b>	inclusive					

The SP 7150TB and SP 7200TB models are fitted with a steel-wire brush and an open protective shield on the left side and are ideal for deburring and derusting of tools and pieces of metalwork.



<b>SP 7150TB</b>	1~
Voltage: 230V 1~ 50-60 Hz	art. 002244
Power: 350 W	
Speed: 2800-3400 rpm	
Steel-wire brush left d1 x b x d2: 150 x 18 x 15 mm	
Grinding wheel right d1 x b x d2: 150 x 20 x 15 mm	

<b>SP 7200TB</b>	1~
Voltage: 230V 1~ 50-60 Hz	art. 002805
Power: 600 W	
Speed: 2800-3400 rpm	
Steel-wire brush left d1 x b x d2: 200 x 22 x 15 mm	
Grinding wheel right d1 x b x d2: 200 x 25 x 15 mm	

# Creusen Powerline Double Polishing Machines

The polishing machines are equipped with conical polishing spindles on the shaft ends and are suitable for many types of polishing work. These machines are suitable for polishing wheels with a diameter of 150 mm and 200 mm.



<b>DPC 7150T</b>	1~
Voltage: 230V 1~ 50-60 Hz	art. 002365
Power: 350 W	
Speed: 2800-3400 rpm	
Polishing wheel d1 x b x d2: 150 x 20 x 15 mm	UK version art. 002376

<b>DPC 7200T</b>	1~
Voltage: 230V 1~ 50-60 Hz	art. 002915
Power: 600 W	
Speed: 2800-3400 rpm	
Polishing wheel left d1 x b x d2: 200 x 20 x 10 mm	UK version art. 002937

## Applications



Polishing wheels, ø 150 mm or ø 200 mm



Polishing covers ensure safety during polishing work



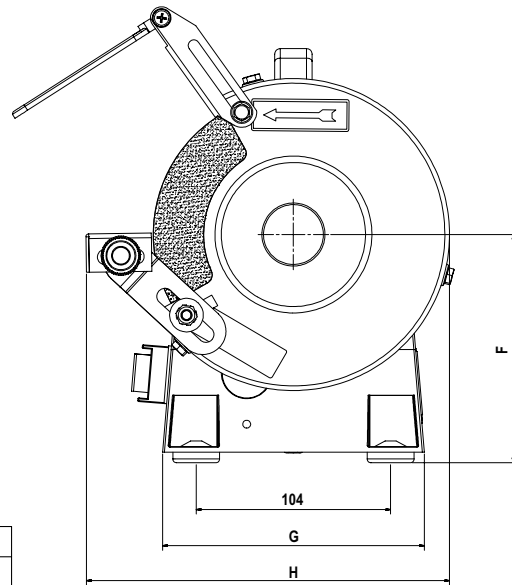
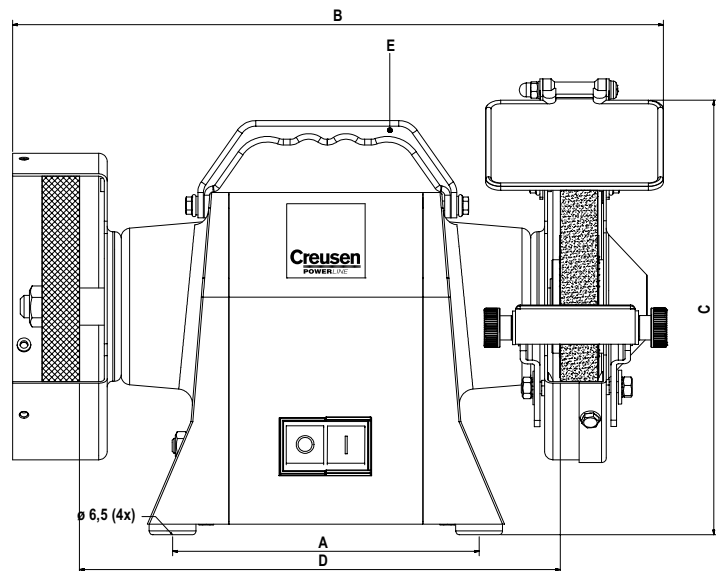

Type	A	B	C	D	E	F	G	H
SP 7150TB	160	350	245	260	●	123	140	200
SP 7200TB	185	415	275	290	-	123	140	260

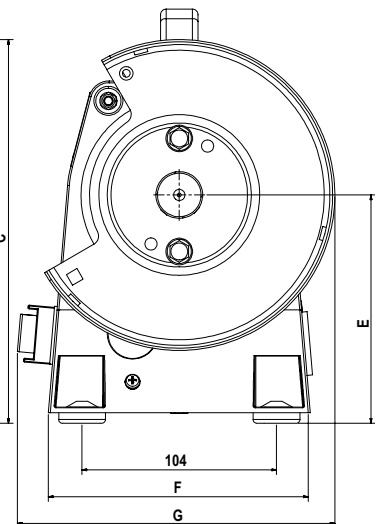
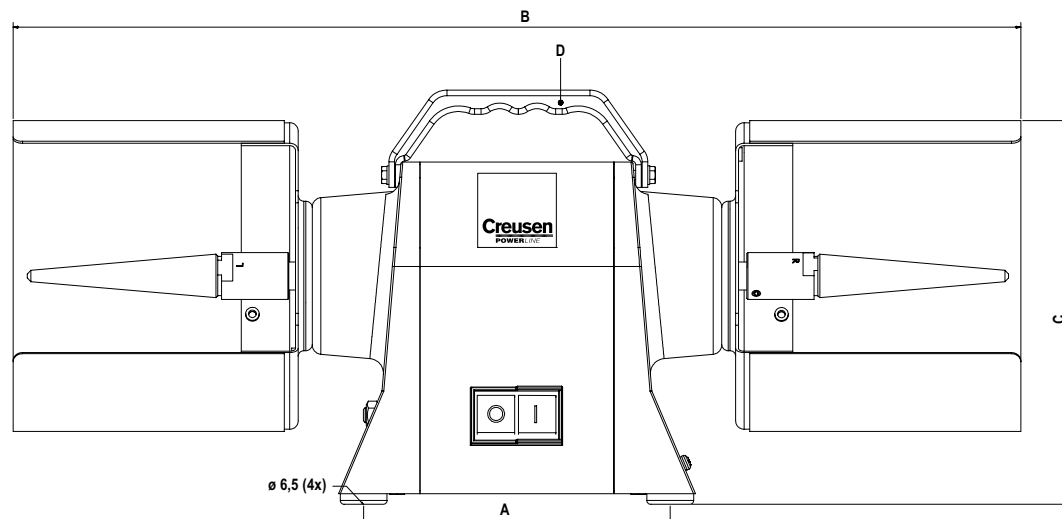

Type	A	B	C	D	E	F	G
DPC 7150T	160	540	210	●	123	140	170
DPC 7200T	185	695	250	-	123	140	220

Type	SP 7150TB 1~	SP 7200TB 1~	DPC 7150T 1~	DPC 7200T 1~	
Voltage (V)	230	230	230	230	
Frequency (Hz)	50-60	50-60	50-60	50-60	
Power (W)	350	600	350	600	
Speed (rpm)	2800-3400	2800-3400	2800-3400	2800-3400	
Peripheral speed (m/s)	22-26	30-36	22-26	30-36	
Steel-wire brush	150 x 18 x 15	200 x 22 x 15			
Grinding wheel d1 x b x d2 (mm)	150 x 20 x 15	200 x 25 x 15			
Grit	80	80			
Polishing wheel d1 x b x d2 (mm) (not standard)			150 x 20 x 15	200 x 20 x 10	
Noise level dB (A)	45	55	45	55	
Weight (kg)	8	13	10	13	
Article number *	002244	002805	002365	002915	
UK version article number			002376	002937	
* Other versions on request					

### Key to codes

- SP** grinder / brushing machine
- DPC** double polishing conical
- 7150** series 7000 / ø 150 mm
- 7200** series 7000 / ø 200 mm
- T** table model
- TB** table model/brush
- inclusive

The knife-sharpening machines are extremely suitable for the professional sharpening of knives, for instance butcher's knives. The machines have a reverse direction of rotation.



## DS 7150MTS

1~

Voltage: 230V 1~ 50-60 Hz

art. 002585

Power: 350 W

Speed: 2800-3400 rpm

Polishing wheel: ø 150 mm

## DS 7200MTS

1~

Voltage: 230V 1~ 50-60 Hz

art. 003025

Power: 600 W

Speed: 2800-3400 rpm

Polishing wheel: ø 200 mm

## Applications



Sharpening knives

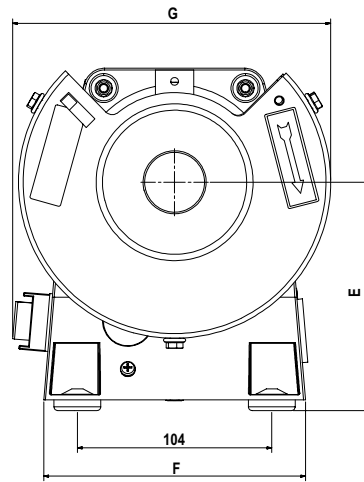
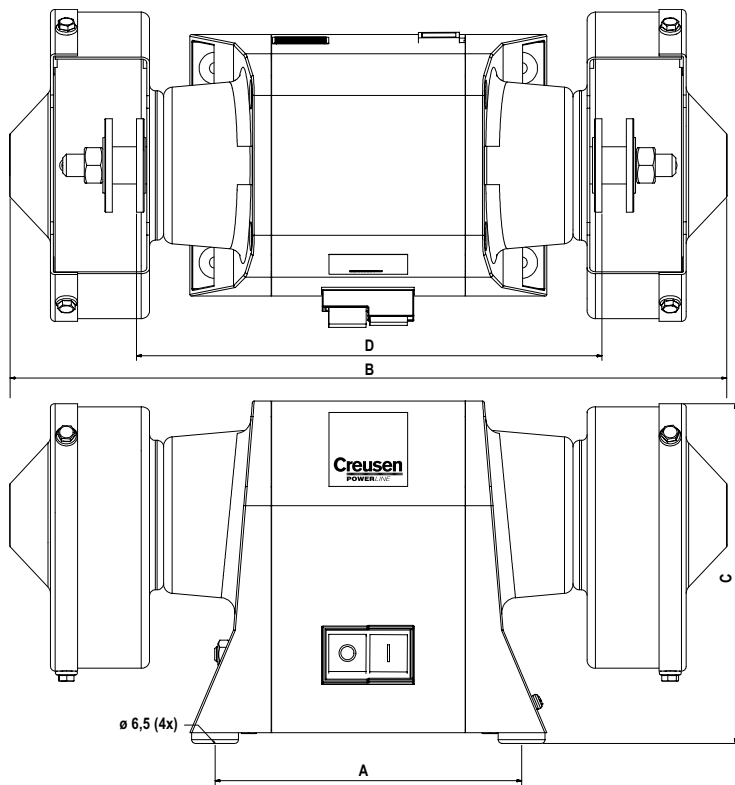

Type	A	B	C	D	E	F	G
DS 7150MTS	160	385	180	247	123	140	170
DS 7200MTS	185	465	205	277	123	140	220

Type	DS 7150MTS 1~	DS 7200MTS 1~
Voltage (V)	230	230
Frequency (Hz)	50-60	50-60
Power (W)	350	600
Speed (rpm)	2800-3400	2800-3400
Peripheral speed (m/s)	22-26	22-26
Polishing wheel (mm) (not standard)	150	200
Noise level dB (A)	45	55
Weight (kg)	8	13
Article number	002585	003025

### Key to codes

- MTS** knife-sharpening machine
- 7150** series 7000 / ø 150 mm
- 7200** series 7000 / ø 200 mm
- T** table model
- S** special protective cover



## Features

- Dutch quality product
- high power rating
- modern design
- low-vibration running
- minimum noise level
- high operational reliability
- versatile thanks to wide range of accessories
- all models in the 7000 series in 220-240 Volt, 1~, 50-60 Hz
- other voltages, e.g. 110 Volt, available on request
- machines carry a CE quality mark and are GS certified
- 5 year warranty



Dutch quality product



Switch in middle of machine for convenient operation



Switch with no-volt release



Practical hand-grip on  $\varnothing$  150 mm machines



Rigid, high strength polycarbonate eye shields



Grinding wheels optimally accessible



Pedestal K 7000 with tool tray and water cup



Stable grinding supports fixed on both sides



Adjustable grinding supports with milled nuts that can be adjusted without tools



Vibration buffers integrated in base



Steel-wire brush for derusting or deburring



Polishing

## Features



Wall console pro-support for placing at desired working height



Extension nut with chuck for deburring drilling holes



Hand dresser for roughening, correcting and cleaning the grinding wheel



Combination chisel sharpening and drill sharpening attachment



Chisel sharpening attachment



Drill sharpening attachment



5 year warranty



Retail pack DS 7150T



Retail pack DS 7150TS

## General



Tapered conical spindle, left  
art. 900152



Tapered conical spindle, right  
art. 900163



Tapered conical spindle mini, left  
For small polishing mops  
art. 900040



Tapered conical spindle mini, right  
For small polishing mops  
art. 900041



Polishing mop linen  
ø 150 x 20 x 15 mm  
art. 700513



Polishing mop flannel  
ø 150 x 20 x 15 mm  
art. 700524



Polishing mop linen  
ø 200 x 20 x 10 mm  
art. 700810



Polishing mop flannel  
ø 200 x 20 x 10 mm  
art. 700821



Polishing paste  
universal  
art. 900240



Polishing cover ø 150 mm  
for right-hand side and  
left-and side per piece  
art. 200574



Polishing cover ø 200 mm  
for right-hand side and  
left-and side per piece  
art. 200563



Polishing set  
ø 150 mm, right  
art. 900245



Polishing set  
ø 200 mm, right  
art. 900250



Extension spindle with  
flanges and nut  
art. 900174



Extension spindle/steel-wire  
brush/extension cover  
art. 900493



Extension nut with chuck,  
10 mm  
art. 900185



Hand dresser  
125 x 20 x 20 mm  
art. 900251



## General



Grinding wheel  
normal corundum  $\varnothing$  150 x  
20 x 15 mm, grit 36,  
**art. 700117**



Grinding wheel  
normal corundum  $\varnothing$  150 x  
20 x 15 mm, grit 80  
**art. 700128**



Grinding wheel aluminium  
oxide  $\varnothing$  150 x 20 x 15 mm,  
grit 100  
**art. 700392**



Cup grinding wheel  
aluminium oxide  $\varnothing$  150 x 40  
x 15 mm, grit 100  
**art. 700139**



Cup grinding wheel  
aluminium oxide  $\varnothing$  150 x 40  
x 15 mm, grit 60  
**art. 700348**



Grinding wheel silicon car-  
bide  $\varnothing$  150 x 20 x 15 mm,  
grit 120, for hard metal  
**art. 700359**



Grinding wheel  
normal corundum  $\varnothing$  200 x  
25 x 15 mm, grit 36  
**art. 700172**



Grinding wheel  
normal corundum  $\varnothing$  200 x  
25 x 15 mm, grit 80  
**art. 700183**



Grinding wheel aluminium  
oxide  $\varnothing$  200 x 25 x 15 mm,  
grit 60, white  
**art. 700216**



Grinding wheel silicon car-  
bide  $\varnothing$  200 x 25 x 15 mm,  
grit 120, for hard metal  
**art. 700381**



Wall console pro-support  
270 x 220 x 180 mm  
**art. 900317**



Pedestal universal K 7000  
**art. 370095**



Tool tray and water cup  
**art. 370128**



Water cup for tool tray  
**art. 900889**

DS 7150T

DS 7150TS



**DS 7150TS:** Combination chisel sharpening and drill sharpening attachment for DS 7150TS art. 900218

**DS 7150T/TS:** Drill sharpening attachment art. 900207

**DS 7150TS:** Chisel sharpening attachment art. 900196



Polishing set right ø 150 mm art. 900245



Wall console pro-support 270 x 220 x 180 mm art. 900317

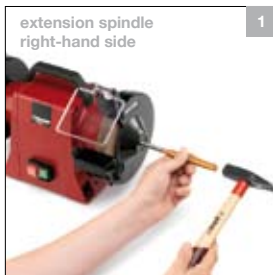

Remove blind plate



Extension spindle for right-hand side

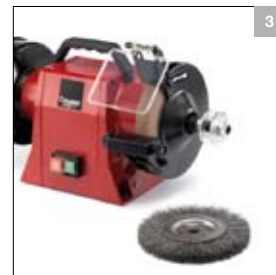

Fixing extension spindle



Fixing steel-wire brush



Fixing protective cover



Steel-wire brush for derusting and deburring many types of tools or objects



Remove blind plate



Extension nut with chuck for right side



Extension nut with chuck for right side

## DS 7200T



Wall console pro-support  
270 x 220 x 180 mm  
art. 900317



Pedestal universal K 7000  
art. 370095



Tool tray and water cup  
art. 370128



Polishing set right ø 200 mm  
art. 900250

## DS 7500TS



Chisel sharpening  
attachment  
art. 900200



Wall console pro-support  
270 x 220 x 180 mm  
art. 900317



Pedestal universal K 7000  
art. 370095



Tool tray and water cup  
art. 370128

## SP 7150TB



**SP 7150TB:**  
Steel-wire brush  
ø 150 x 18 x 15 mm  
art. 700601



**SP 7200TB:**  
Steel-wire brush  
ø 200 x 22 x 15 mm  
art. 700480

## DPC 7150T



Polishing mop linen  
ø 150 x 20 x 15 mm  
art. 700513



Polishing mop flannel  
ø 150 x 20 x 15 mm  
art. 700524



Polishing mop linen  
ø 200 x 20 x 10 mm  
art. 700810



Polishing mop flannel  
ø 200 x 20 x 10 mm  
art. 700821



Polishing paste  
universal  
art. 900240





Switch with no volt release  
art. 449009



Switch with safety cover  
black  
(former model)  
art. 449812



Grinding support  
DS 7150T per 2 pieces  
art. 1330098



Grinding support  
DS 7150TS per 2 pieces  
art. 1330087



Grinding support  
DS 7200T per 2 pieces  
art. 1330076



Grinding support  
DS 7500TS per 2 pieces  
art. 1330090



Eye shield universal  
polycarbonate per 2 pieces  
art. 900009



Eye shield with spark  
arrestor per 2 pieces  
DS 7150T  
art. 900900



Eye shield with spark  
arrestor per 2 pieces  
DS 7150TS  
art. 900911



Eye shield with spark  
arrestor per 2 pieces  
DS 7200T  
art. 900922



Eye shield with spark  
arrestor per 2 pieces  
DS 7500TS  
art. 900928



Eye shield bracket per piece  
(former model)  
art. 200310



Wheel guard with cover  
DS 7150T left  
art. 1330010



Wheel guard with cover  
DS 7150T and TS right  
art. 1330021



Wheel guard with cover  
DS 7150TS left  
art. 1330032



Wheel guard with cover  
DS 7500TS right  
art. 1330043



Wheel guard with cover  
DS 7200T left  
art. 1330054



Wheel guard with cover  
DS 7200T right  
art. 1330065



Capacitors  
5uf DS 7150T/TS **art. 460031**  
8uf DS 7200T/7500TS  
**art. 460053**

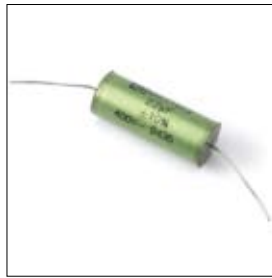

Capacitor 2,2 uf 400V  
(former model)  
**art. 460273**



Buffers per 4 pieces  
**art. 560175**



Flange DS 7150T/TS  
50/15.1 x 4 mm  
**art. 200420**

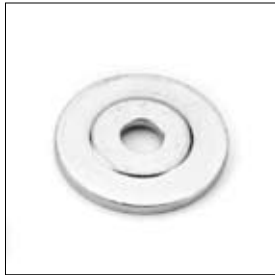

Flange DS 7150T/TS  
50/12.1 x 4 mm  
**art. 200409**



Flange DS 7200T  
70/15.1 x 6 mm  
**art. 200442**



Flange DS 7200T  
70/12.1 x 6 mm  
**art. 200453**



Spacer 20/15 x 10 mm  
for DS 7150T/TS  
**art. 280148**



Spacer 20/15 x 15 mm  
for DS 7200  
**art. 280115**



Spacer 20/15 x 8 mm for  
accessories  
**art. 280104**



Nut M12 left  
**art. 668558**



Nut M12 right  
**art. 668437**

The double grinding machines (DS) are fitted with grinding wheels with diameters of 200 mm, 250 mm and 300 mm respectively. They are characterised by their high, progressive power ratings which are more than sufficient for heavy-duty industrial grinding and deburring work.





## DS 9200

1~

Voltage: 230V 1~ 50-60Hz

Power: 900 W

Speed: 2800-3400 rpm

Grinding wheel d1 x l x d2: 200 x 25 x 20 mm

UK version art. 007227

art. 007216



## DS 9250

3~

Voltage: 400/230V 3~ 50-60Hz

Power: 1500 W

Speed: 2800-3400 rpm

Grinding wheel d1 x l x d2: 250 x 30 x 20 mm

art. 007469

## DS 9200

3~

Voltage: 400/230V 3~ 50-60Hz

Power: 1100 W

Speed: 2800-3400 rpm

Grinding wheel d1 x l x d2: 200 x 25 x 20 mm

art. 007304

## DS 9250

3~

Voltage: **525V 3~ 50-60 Hz**

Power: 1500 W

Speed: 2800-3400 rpm

Grinding wheel d1 x l x d2: 250 x 30 x 20 mm

art. 007491

**NEW  
525 V**



## DS 9300

3~

Voltage: 400/230V 3~ 50-60 Hz

Power: 1700 W

Speed: 1400-1700 rpm

Grinding wheel d1 x l x d2: 300 x 40 x 25 mm

art. 007557

### Key to codes

<b>DS</b>	double grinder
<b>9200</b>	series 9000 / ø 200 mm
<b>9250</b>	series 9000 / ø 250 mm
<b>9300</b>	series 9000 / ø 300 mm
<b>B</b>	brake





## DS 9200-B

3~

with brake

Voltage: 400/230V 3~ 50-60Hz

art. 007315-B

Power: 1100 W

Speed: 2800-3400 rpm

Grinding wheel d1 x l x d2: 200 x 25 x 20 mm



## DS 9250-B

3~

with brake

Voltage: 400/230V 3~ 50-60Hz

art. 007480-B

Power: 1500 W

Speed: 2800-3400 rpm

Grinding wheel d1 x l x d2: 250 x 30 x 20 mm



## DS 9300-B

3~

with brake

Voltage: 400/230 V 3~ 50-60 Hz

art. 007590-B

Power: 1700 W

Speed: 1400-1700 rpm

Grinding wheel d1 x l x d2: 300 x 40 x 25 mm

## Features

- Dutch quality product
- versatile
- perfectly balanced
- low-vibration running
- low noise level
- suitable for assembling on pedestal
- 5 year warranty



Dutch quality product



Switch with no-volt release and emergency stop

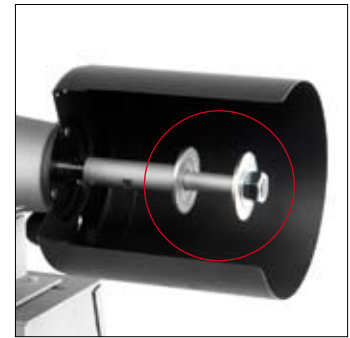

Extension shaft for right-hand side of DS 9200 and DS 9250, distance between flanges 60 mm



Conical spindle for right-hand side of DS 9200 and DS 9250



Steel-wire brush fitted inside wheel guard to replace grinding wheel



Grinding wheels easily accessible



Cast iron grinding support  
High closed protective cover for optimum safety



Extremely suitable for assembling on pedestal AK 9000HD with integrated extraction



A second connection point is fitted as standard at the back of the machine base for mounting on pedestal AK 9000HD



Dust extractor connection on both sides, ø 50 mm



Pedestal universal K 9000HD thick walled steelplate, 4 mm

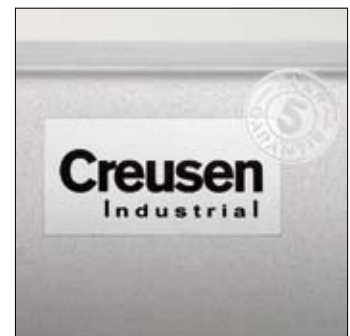

5 year warranty



## Accessories



Extension spindle  
DS 9200/9250 left  
shaft ø 20 mm  
**art. 900537**



Extension spindle  
DS 9200/9250 right  
shaft ø 20 mm  
**art. 900471**



Conical spindle left  
DS 9200/9250  
shaft ø 20 mm  
**art. 900526**



Conical spindle right  
DS 9200/9250  
shaft ø 20 mm  
**art. 900515**



Polishing mop linen  
ø 200 x 20 x 10 mm  
**art. 700810**



Polishing mop flannel  
ø 200 x 20 x 10 mm  
**art. 700821**



Polishing mop linen  
ø 300 x 30 x 20 mm  
**art. 700825**



Polishing mop flannel  
ø 300 x 30 x 20 mm  
**art. 700830**



Polishing paste  
universal  
**art. 900240**



Polishing cover ø 200 mm  
left with dust extractor  
connection ø 50 mm  
**art. 202411**



Polishing cover ø 200 mm  
right with dust extractor  
connection ø 50 mm  
**art. 202422**



Polishing cover ø 300 mm  
left with dust extractor  
connection ø 50 mm  
**art. 202433**



Polishing cover ø 300 mm  
right with dust extractor  
connection ø 50 mm  
**art. 202444**



Steel-wire brush  
ø 200 x 22 x 20 mm  
with spacers  
**art. 700403**



Steel-wire brush  
ø 250 x 22 x 20 mm  
with spacers  
**art. 700414**



## Accessories



Steel-wire brush  
 ø 300 x 26 x 25 mm  
 with spacers  
**art. 700425**



Hand dresser for roughening,  
 correcting and cleaning  
 the grinding wheel,  
 150 x 25 x 25 mm **art. 900284**



Grinding wheel  
 ø 200 x 25 x 20 mm,  
 grit 36  
**art. 700238**



Grinding wheel  
 ø 200 x 25 x 20 mm,  
 grit 80  
**art. 700249**



Grinding wheel  
 ø 200 x 25 x 20 mm,  
 grit 60, white  
**art. 700216**



Grinding wheel  
 ø 250 x 30 x 20,  
 grit 36  
**art. 700260**



Grinding wheel  
 ø 250 x 30 x 20 mm,  
 grit 80  
**art. 700271**



Grinding wheel  
 ø 300 x 40 x 25 mm,  
 grit 60  
**art. 700315**



Grinding wheel  
 ø 300 x 40 x 25 mm,  
 grit 36  
**art. 700304**



Pedestal AK 9000HD with  
 integrated dust extraction  
**art. 007425**



Pedestal universal  
 K 9000HD  
 thick walled steelplate, 4mm  
**art. 007436**



Tool tray and water cup for  
 pedestal  
**art. 370117**



Water cup for tool tray  
**art. 900889**

## Parts



Switch with no-volt release and emergency power cut off  
**art. 449042**



Emergency power cut off button  
**art. 251889**



Capacitor 16uf for DS 9200 1-  
**art. 460262**



Eye shield set for DS 9200 per 2 pieces  
**art. 900339**



Eye shield DS 9250/9300 per piece  
**art. 250261**



Eye shield DS 9250/9300 with spark arrester per piece  
**art. 900306**



Protective cover DS 9200 left  
**art. 901450**



Protective cover DS 9200 right  
**art. 901461**



Protective cover DS 9250 left  
**art. 901472**



Protective cover DS 9250 right  
**art. 901483**



Protective cover DS 9300 left  
**art. 901494**



Protective cover DS 9300 right  
**art. 901505**



Grinding support DS 9200 left  
**art. 902176**



Grinding support DS 9200 right  
**art. 902165**



Grinding support DS 9250/9300 left  
**art. 902198**



Grinding support DS 9250/9300 right  
**art. 902187**



Flange DS 9200 per piece  
**art. 200893**



Flange DS 9250 without cam **art. 1345012**  
with cam **art. 1345001**



Flange DS 9300 without cam **art. 1345034**  
with cam **art. 1345023**

## Parts



Nut M20 left  
art. 668602



Nut M20 right  
art. 668481



Cam safety ring for machine  
with brake  
art. 680372



Extractor motor N302  
for pedestal AK 9000HD  
art. 780021



PVC hose for AK 9000 per  
piece  
art. 251856



Filter for pedestal  
AK 9000HD 310 x 290 mm  
art. 900735

To complete the range of grinding machines, we offer the industrial user a very stable, steelplate pedestal in two versions: with or without integrated dust extraction.

DS 9300 on pedestal AK 9000HD



#### Key to codes

- AK** pedestal with integrated dust extraction
- K** pedestal
- 9000** series 9000
- HD** heavy duty

**Creusen**  
Industrial





## AK 9000HD

Voltage: 400/230V 3~ 50-60 Hz

art. 007425

Power: 180 W

Speed: 2800-3400 rpm

## K 9000

art. 007436



## AK 9000HD

rear view

Voltage: 400/230 V 3~

art. 007425

Power: 180 W

Speed: 2800-3400 rpm

- Height 85 cm
  - Thick walled steelplate (4 mm)
  - With integrated dust extraction
- 400/230V 3~
- Machines are supplied as standard without a pedestal

### Key to codes

- AK** pedestal with integrated dust extraction
- K** pedestal
- 9000** series 9000
- HD** heavy duty

## Features

- Dutch quality product
- thick walled steelplate (4 mm)
- stable
- extractor motor integrated
- suitable for all three-phase Creusen Industrial grinders series 9000
- machine and dust extractor operated by single switch with no-volt release
- motor, fan, dust extractor and dust collector integrated in pedestal
- extractor unit fitted with radial fan
- 5 year warranty



Dutch quality product



Pedestal AK 9000HD with integrated dust extraction



Pedestal universal K 9000HD thick walled steelplate, 4mm



Tool tray and water cup



Collector tray with filter



Baseplate fixing at four corners



Switch with no-volt release and emergency stop



A second connection point is fitted as standard at the back of the machine base for mounting on pedestal AK 9000HD



Dust extractor connection on both sides, ø 50 mm

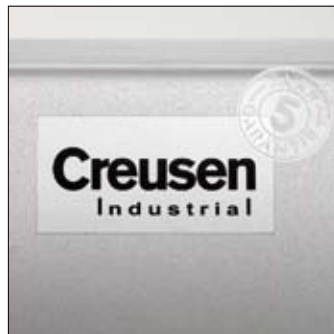

5 year warranty

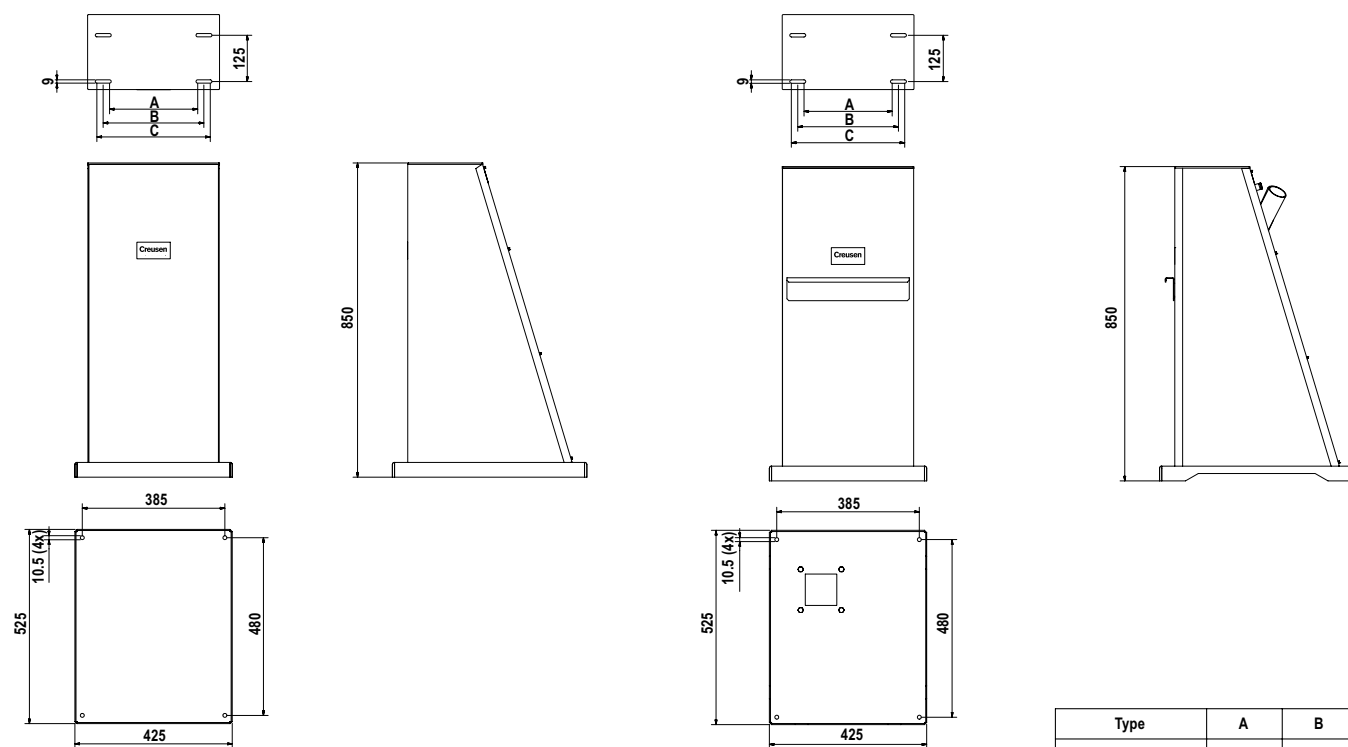

Type	A	B	C
9200	240	-	-
9250	-	253	-
9300	-	-	304

Type	AK 9000HD 3~	K 9000HD
Extractor motor	N302	
Voltage (V)	400/230	
	3~	
Frequency (Hz)	50-60	
Power (kW)	0,18	
Speed (rpm)	2800-3400	
Capacity m <sup>3</sup> /h	600	
Hose connection (mm)	2 x ø 50	
Height	850	850
Dimensions upper plate (mm)	356 x 203	356 x 203
Dimensions bottom plate (mm)	425 x 525	425 x 525
Noise level dB (A)	70	
Weight (kg)	40	30
Dimensions filter (mm)	310 x 290	
Article number	007425	007436
<b>Key to codes</b>		
<b>AK</b>	pedestal with integrated dust extraction	
<b>K</b>	pedestal	
<b>9000</b>	series 9000	
<b>HD</b>	heavy duty	

## Accessories and Parts



Tool tray and water cup for pedestal  
**art. 370117**



Water cup for tool tray  
**art. 900889**



Extractor motor N302 for pedestal AK 9000HD  
**art. 780021**



PVC hose for AK 9000HD  
per piece  
**art. 251856**



Filter for pedestal  
AK 9000HD 310 x 290 mm  
**art. 900735**